

EUROSTYLE®



**Jib cranes: mounted on a wall
or on a column, with total or partial
rotation capability, manual or motorized.**

 **VERLINDE**
LIFTING EQUIPMENT
EMMEGIESSE s.r.l.

Via Giovanni Falcone N° 8 41057 Spilamberto (MO) Italy
Tel 059/785979 Fax 059/785937 - www.emmegiesse.com - info@emmegiesse.com

Wall-mounted jib crane

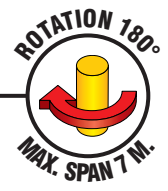

EUROSTYLE VAT & VATS overbraced wall-mounted jib crane

These are the most inexpensive jib cranes if you have a wall or a post that is strong enough, close to the workstation it will service. The height available under the iron beam is only limited by the height of the building itself. The main feature is the arm: to ensure easy rotation, the arm is articulated in the two captive hinges in the two projecting support members that make up the anchor plate.

2 models

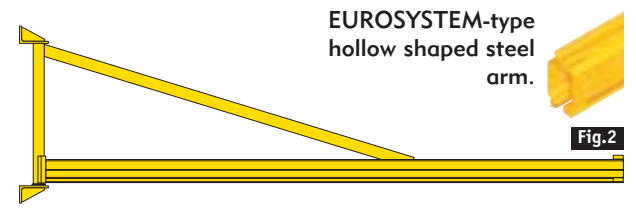
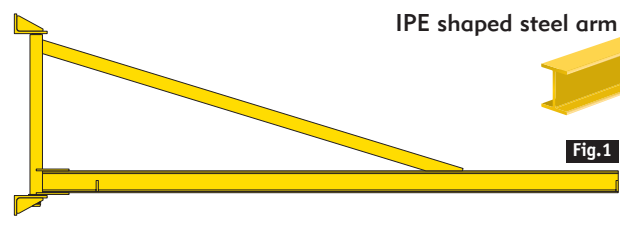

EUROSTYLE VAT, with a load capacity from 125 to 3,000 kg, and span is 2 to 6 meters max. (Fig 1)

EUROSTYLE VATS, with a load capacity from 125 to 2,000 kg, and span is 2 to 7 meters max. (Fig 2)



EUROSTYLE VAI underbraced wall-mounted jib crane

This type of jib cranes provides greater lifting height than a underbraced jib cranes with the same features. Its main feature is the arm: to ensure easy rotation, the arm is articulated in the two captive hinges in the two projecting support members that make up the anchor plate.

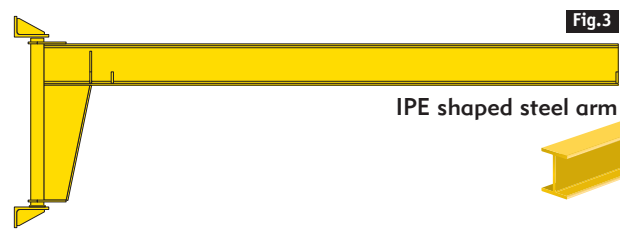

EUROSTYLE VAI, with a load capacity from 125 to 3,000 kg, and span is 2 to 6 meters max. (Fig 3)

Technical characteristics and optional features

Load capacity

Load capacity	Span in meters					
	2	3	4	5	6	7
125 kg	◆●▲	◆●▲	◆●▲	◆●▲	◆●▲	▲
250 kg	◆●▲	◆●▲	◆●▲	◆●▲	◆●▲	▲
500 kg	◆●▲	◆●▲	◆●▲	◆●▲	◆●▲	▲
1.000 kg	◆●▲	◆●▲	◆●▲	◆●▲	◆●▲	
1.600 kg	◆●▲	◆●▲	◆●▲	◆●	◆●	
2.000 kg	◆●▲	◆●▲	◆●	◆●	◆●	
3.000 kg	◆●	◆●	◆●	◆●	◆●	

◆: VAT ●: VAI ▲: VATS

Electric power supply to the hoist

Two kinds available, depending on the type of hoist:
 • Either by means of flat cable feeding line parallel to the beam
 • Or by means of flat cable trolleys inside the profile (EUROSYSTEM-type hollow shaped steel beam).

Options available for these jib cranes

- Adjustable stop for trolley
- mechanical rotation stops
- Jib cranes can be delivered with or without electrical equipment (power supply line, safety switch and rising main).

IMPORTANT: maximum authorized lifting speed: 16 m/min.

Column-mounted jib crane



EUROSTYLE VFT and VFTS overbraced column-mounted jib crane

These are overbraced wall-mounted jib cranes attached to a steel tube column fitted into a round base reinforced with 6 or 8 stiffeners, depending on load capacity and span.

They are completely independent from the building. Anchorage needs to be installed because they must be anchored to the ground.

2 models

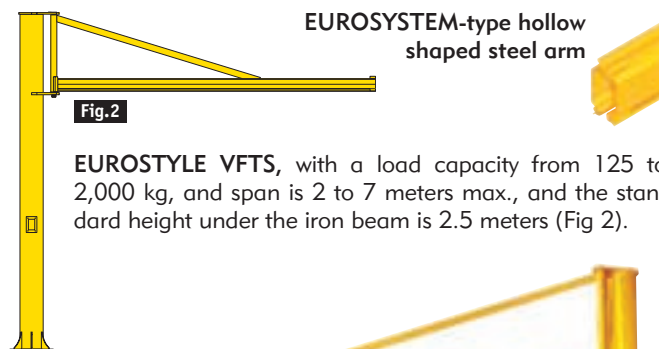
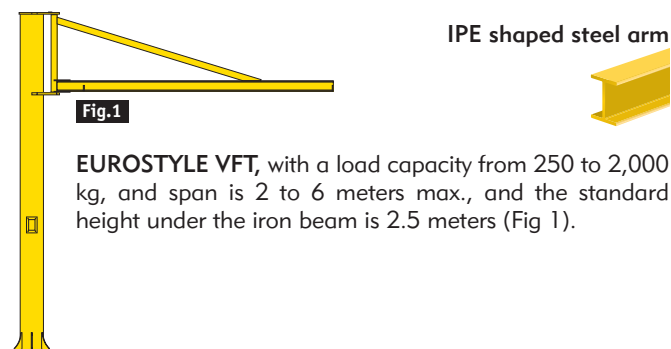

EUROSTYLE VFI underbraced column-mounted jib crane

270° rotation over a 6-meter max. span. These are underbraced wall-mounted jib cranes attached to a steel tube column fitted into a round base reinforced with 6 or 8 stiffeners, depending on strength and span.

They are completely independent from the building. Concrete foundation needs to be done before fixing the jib crane by means of anchor bolts and template.

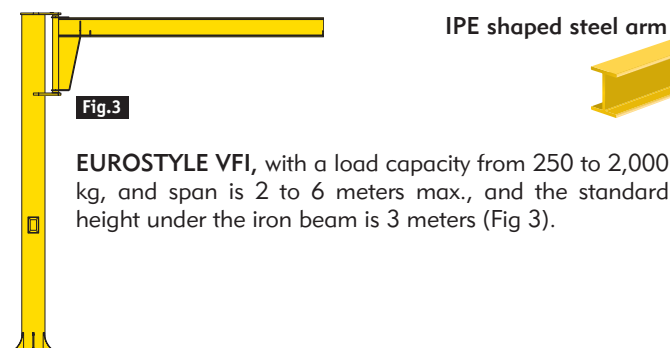

Technical characteristics and optional features

Load capacity

Load capacity	Reach in meters					
	2	3	4	5	6	7
125 kg	▲	▲	▲	▲	▲	▲
250 kg	◆●▲	◆●▲	◆●▲	◆●▲	◆●▲	▲
500 kg	◆●▲	◆●▲	◆●▲	◆●▲	◆●▲	▲
1.000 kg	◆●▲	◆●▲	◆●▲	◆●▲	●▲	
1.600 kg	◆●▲	◆●▲	●▲	◆●	◆●	
2.000 kg	◆●▲	●▲	●			

◆: VFT ●: VFI ▲: VFTS

- Or by means of flat cable trolleys inside the profile (EUROSYSTEM-type hollow shaped steel beam).

Options available for these jib cranes:

- Anchor bolts and template
- Adjustable stop for trolley
- Mechanical rotation stop
- Square base
- Rotation-blocking mechanism
- Jib cranes can be delivered with or without electrical equipment (power supply line, safety switch and rising main).

Electric power supply to the hoist

Two kinds available, depending on the type of hoist:

- Either by means of flat cable feeding line parallel to the beam

IMPORTANT: maximum authorized lifting speed: 16 m/min.

Fully rotating column-mounted jib crane



EUROSTYLE VFP & VFM fully rotating column-mounted angle bracket

2 models

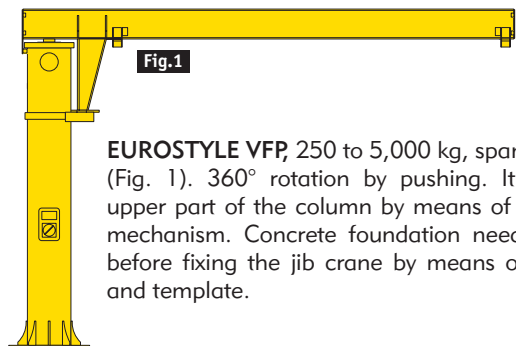

EUROSTYLE VFP, 250 to 5,000 kg, span 2 to 6 meters (Fig. 1). 360° rotation by pushing. It turns on the upper part of the column by means of a ball bearing mechanism. Concrete foundation needs to be done before fixing the jib crane by means of anchor bolts and template.

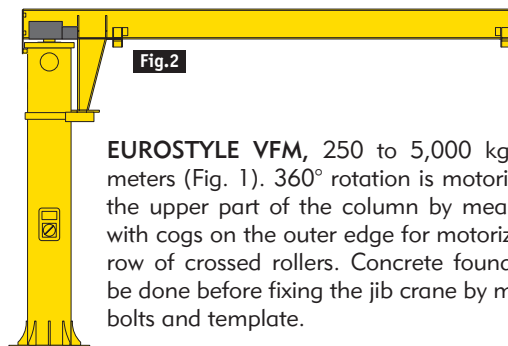

EUROSTYLE VFM, 250 to 5,000 kg, span 2 to 6 meters (Fig. 1). 360° rotation is motorized. It turns on the upper part of the column by means of ring gear with cogs on the outer edge for motorization, with one row of crossed rollers. Concrete foundation needs to be done before fixing the jib crane by means of anchor bolts and template.

These jib cranes take up a small amount of space but provide maximum lifting height capability. They are made up of three parts: a steel tube column, connected to – and forming a single unit with – a welded base that is reinforced with 6 or 8 ribs; a head that revolves at the top of the column by means of bearings; an IPE shaped steel arm connected to – and forming a single unit with – the head.

Technical characteristics and optional features

Electric rotation with one or two speeds (two speed standard)

A rotation motor-reducer unit with an adjustable torque limiter for gradual start and stop of the rotating movement.

Two types of driving effect:

- For use inside the building and span below 8 m. The movement is done by two friction rollers on a machined surface.
- For use outdoors and span above 8 m. Driving action is accomplished by a pinion and ring gear with cogs. Rotating speeds (depending on each type) are indicated in the technical instructions with reference EUROSTYLE VFM 360.



The push button box operates with very low voltage for safety. ON - OFF is optional. It is possible to control it using direct voltage.

Electric power supply to the hoist

By means of a flexible, flat cable parallel feeding line. One end of the cable is connected to the hoist's control panel. The other end is connected to an electrical connection box on the wall or on the jib crane column.

Options available for these jib cranes:

- Anchor bolts and template
- Adjustable stop for trolley
- Mechanical rotation stop
- Square base



Rotation control

There are two types: the push button box attached to the hoist, or the push button box that can be moved along the arm.

IMPORTANT: maximum authorized lifting speed: 16 m/min.

Load capacity

Load capacity	Span in meters																					
	2	2,5	3	3,5	4	4,5	5	5,5	6	6,5	7	7,5	8	8,5	9	9,5	10	10,5	11	11,5	12	
125 kg	✓	✓	✓	✓	✓	✓	✓	✓	✓	✓	✓	✓	✓	✓	✓	✓	✓	✓	✓	✓	✓	✓
250 kg	✓	✓	✓	✓	✓	✓	✓	✓	✓	✓	✓	✓	✓	✓	✓	✓	✓	✓	✓	✓	✓	✓
500 kg	✓	✓	✓	✓	✓	✓	✓	✓	✓	✓	✓	✓	✓	✓	✓	✓	✓	✓	✓	✓	✓	✓
1.000 kg	✓	✓	✓	✓	✓	✓	✓	✓	✓	✓	✓	✓	✓	✓	✓	✓	✓	✓	✓	✓	✓	✓
1.600 kg	✓	✓	✓	✓	✓	✓	✓	✓	✓	✓	✓	✓	✓	✓	✓	✓	✓	✓	✓	✓	✓	✓
2.000 kg	✓	✓	✓	✓	✓	✓	✓	✓	✓	✓	✓	✓	✓	✓	✓	✓	✓	✓	✓	✓	✓	✓
2.500 kg	✓	✓	✓	✓	✓	✓	✓	✓	✓	✓	✓	✓	✓	✓	✓	✓	✓	✓	✓	✓	✓	✓
3.200 kg	✓	✓	✓	✓	✓	✓	✓	✓	✓	✓	✓	✓	✓	✓	✓	✓	✓	✓	✓	✓	✓	✓
4.000 kg	✓	✓	✓	✓	✓	✓	✓	✓	✓	✓	✓	✓	✓	✓	✓	✓	✓	✓	✓	✓	✓	✓
5.000 kg	✓	✓	✓	✓	✓	✓	✓	✓	✓	✓	✓	✓	✓	✓	✓	✓	✓	✓	✓	✓	✓	✓
6.300 kg	✓	✓	✓	✓	✓	✓	✓	✓	✓	✓	✓	✓	✓	✓	✓	✓	✓	✓	✓	✓	✓	✓
8.000 kg	✓	✓	✓	✓	✓	✓	✓	✓	✓	✓	✓	✓	✓	✓	✓	✓	✓	✓	✓	✓	✓	✓
10.000 kg	✓	✓	✓	✓	✓	✓	✓	✓	✓	✓	✓	✓	✓	✓	✓	✓	✓	✓	✓	✓	✓	✓

VFP 360

VFM 360

Greater capacity and span capabilities are available. Contact us for more information.

“Templier” jib crane with articulated arm 50 to 1,000 kg.

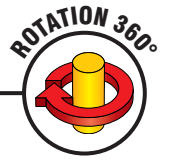

Choosing the jib crane

The “Templier” articulated jib crane by VERLINDE can easily handle loads from 50 to 1,000 kg., over a 5 to 2 m span, almost full circle, and practically no dead space (the articulated arm allows working around obstacles; see the picture below).

Ball bearings are greased during assembly so it can be used without regular upkeep. However, once a year you should make sure the bolts on the jib crane and the point of attachment are properly tightened.

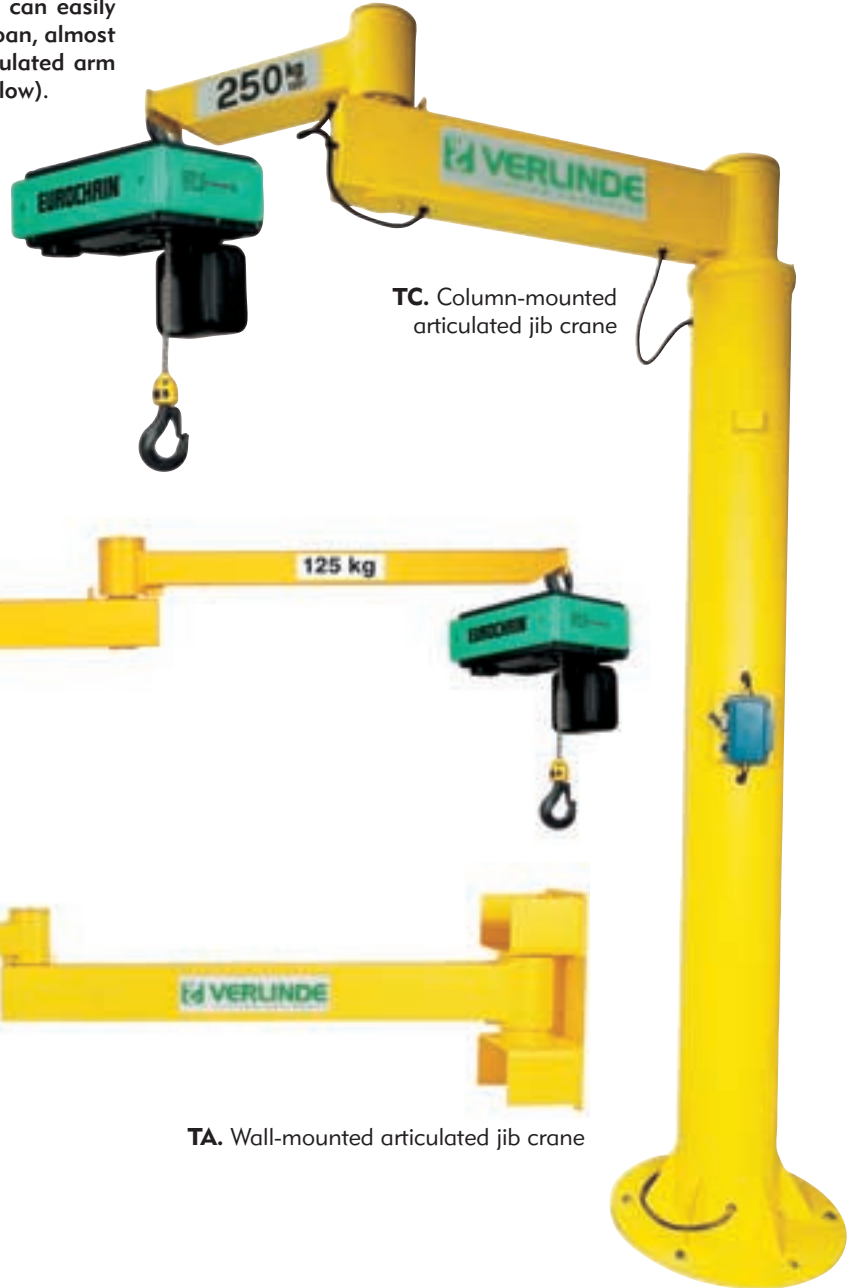
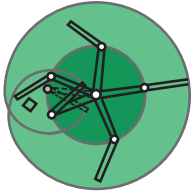

TC. Column-mounted articulated jib crane

TSR. Articulated jib crane attached to ceiling

TA. Wall-mounted articulated jib crane

“Templier”, TC, TA and TSR range of jib cranes

Load capacity (kg)	Span (m)	Jib crane type	Model				
			On TC-type column (height under iron beam)			TA wall-mounted	TSR ceiling-mounted
			3m	4m	5m		
50	5	1	●	●	●	●	●
80	4	1	●	●	●	●	●
125	3	1	●	●	●	●	●
250	2	1	●	●	●	●	●
125	5	2	●	●	●	●	●
250	4	2	●	●	●	●	●
500	3	2	●	●	●	●	●
1.000	2	2	●	●	●	●	●

VEP jib crane

Manual stainless steel jib crane 125 to 250 kg.

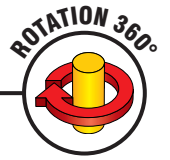

Applications

Designed especially for use in handling pumps, agitators, etc. The design of the VEP jib crane is the result of the joint work of French water treatment engineering firms and VERLINDE, the number one French designer and manufacturer of lifting and handling equipment.

The main design criteria, its execution and particularly careful monitoring provide the VEP jib crane with the qualities it requires to be used at a water treatment plant.

The fact that it is made out of stainless steel also makes it ideal for use in the food-processing industry.



Features



As it weighs only 37 kg., this stainless steel angle bracket can be moved with ease to other fixed bases.



A **standard design**, which allows for complete interchangeability of its parts

- **Span:** 0.8 to 1,000 mm
- **Load:** up to 250 kg. using PHD manual hoist
- **Installation:** versatile multi-use base can be attached to concrete surface, using a wall fixture, or by embedding it into an anchor post.



The structure is made entirely out of **304 L. STAINLESS STEEL**, ideal for a corrosive environment (including the versatile multi-position base and the chemical bolts.



Rounded bottom. Molygraphite greasing of the wear rings, ensuring even easier rotation.



Two handles to provide easy transport and rotation. Rotation torque with maximum load (250 kg.) with lever arm 1m < 30 kg.

Technical information

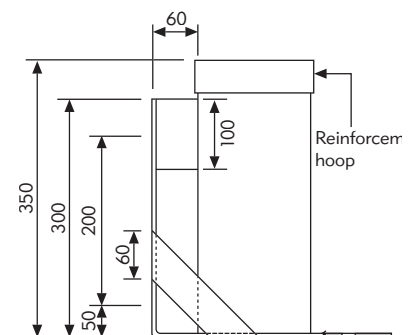
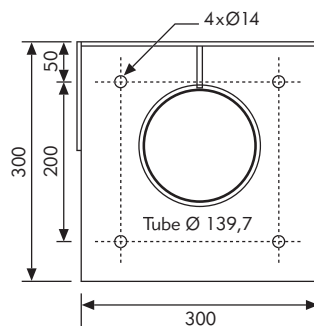
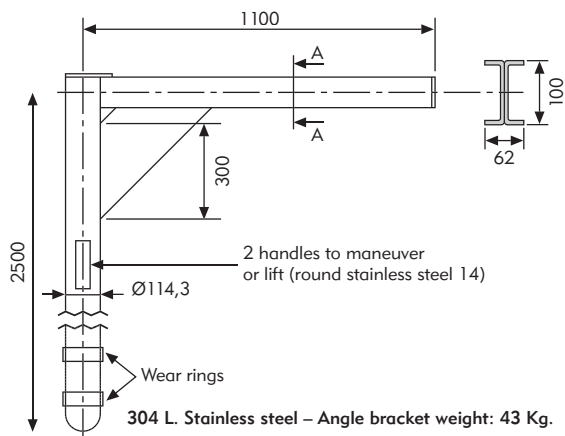

Information required to prepare an estimate

For jib cranes: VAT, VAI, VATS, VFI, VFT, VFTS, VFP, VFM, VEP, "Templiers".

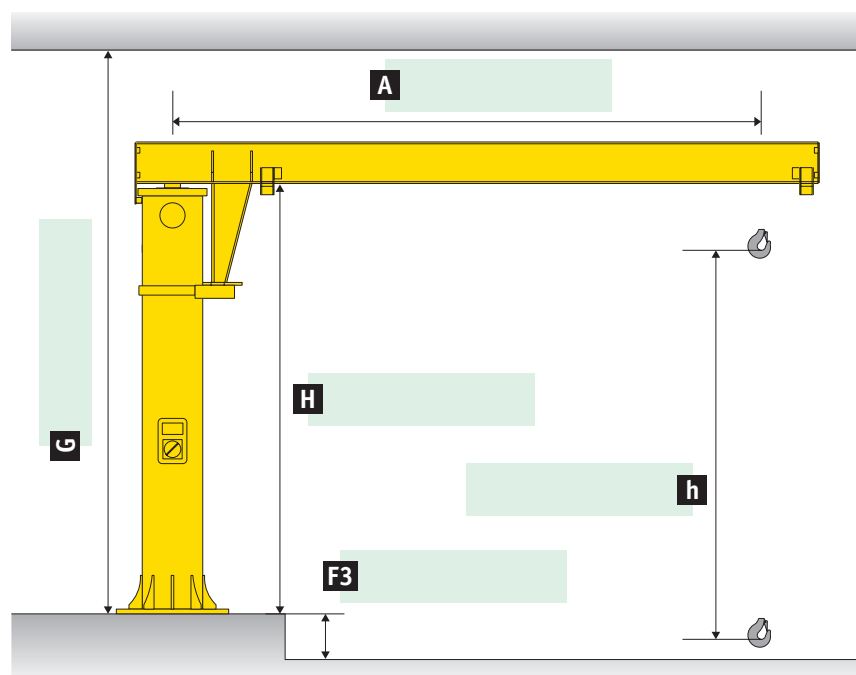

Additional items to value "Templier" jib cranes.

TC jib crane

- Height from the ground to the point where the hoist is attached
- Area free of obstacles above the installation surface

TA jib crane

- Space available above and below the elevation measured
- Type of support and dimensions (metal beam, concrete beam, wall.)
- Location of potential obstacles.

Type of jib crane: VAT, VAI, VATS, VFI, VFT, VFTS, VFP, VFM, VEP, "Templiers".

- Maximum load that can be lifted.
- Span A: distance from the rotation axis to the axis of the trolley that carries the hoist
- Height under jib crane arm: **H**.
- Desired lifting height: **h**.
- Height from control level to floor: **F3** (for an electric hoist).

- Area free of obstacles above the installation surface: **G**.
- Voltage and frequency of electric current for jib cranes with electric hoists.
- Planned use: loading, maintenance, production, etc.
- Indoor or outdoor service.
- Rate of use (light, medium, heavy use).
- Air (normal, dusty, corrosive, humid).
- Type of hoist desired.

VERLINDE is:

- The Number 1 French exporter and manufacturer of lifting and handling equipment.
- Backed up by a staff of 5,000 in the Group.
- Offering a range of 30 lifting products
- ISO 9001 quality assurance certification
- With presence in over 80 countries.



In France

9 points of sale, 14 after-sales service stations, 11 manufacturing plants that manufacture EUROPONT traveling cranes, a distribution network.

Rest of the World:

Branches in Germany, Holland, Belgium, Italy and distributors in Germany, Argentina, Austria, Brazil, Chile, Ireland, United Kingdom, Sweden, Norway, Denmark, China, Thailand, Indonesia, Malaysia, United States, etc.

 **VERLINDE**
LIFTING EQUIPMENT
EMMEGIESSSE s.r.l.

Via Giovanni Falcone N° 8 41057 Spilamberto (MO) Italy
Tel 059/785979 Fax 059/785937 - www.emmegiesse.com - info@emmegiesse.com



EMMEGIESE